

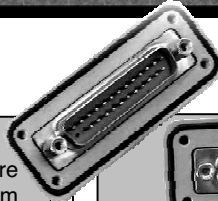

Positronic Industries
www.connectpositronic.com

HERMETIC FEEDTHROUGH FOR SPACE OR INDUSTRIAL VACUUM APPLICATIONS

XAVAC®



XAVAC® Series Connectors are D-Subminiature feedthroughs for SPACE or INDUSTRIAL vacuum applications.

Both sides contain four threaded mounting holes, an o-ring groove and fixed female jackscrews. These redundant features allow either side of the connector to be mounted toward the vacuum, giving the customer the ultimate in flexibility.

The type of contacts is according to the customer request: with normal density insulators 9, 15, 25, 37, and 50 contacts (AWG20): Male/Female, Male/Male, or Female/Female. With high density insulators: 15, 26, 44, 62, 78 and 104 contacts (AWG22): Male/Female. With mixed contact combinations (Power, Coaxial, and Signal contacts): Male/Female.

All XAVAC® Series connectors are 100 % leak tested after fabrication.

In addition to the standard options, Positronic can supply XAVAC® connectors as board mount varieties or with flying leads.

XAVAC® series connectors utilize precision machined contacts for strength and durability. The materials and finishes, as well as the technical characteristics of the XAVAC® series connectors conform to MIL-DTL-24308, Goddard and the SPACE-D32 specifications.

MATERIALS AND FINISHES

Insulator:	Glass-filled DAP per ASTM-D-5948 or polyester glass-filled per ASTM D 5927, UL94V0, ASTM E-595, NASA-RP-1124.
Contacts:	Precision machined copper alloy.
Posiband Spring Clip:	BeCu (Copper alloy).
Contact Plating:	0,000050 inch (1,25 microns) gold over copper plate.
Shells:	Brass with 0,000050 inch (1,25 microns) gold over copper plate or stainless steel.
Housing:	Aluminium alloy, golden brown conversion coating.
O-ring:	Viton (fluorocarbon). Other material per request. One mounting and one for spare part.

MECHANICAL CHARACTERISTICS

Fixed Contacts:	Size 8 Contact: 0,142 inch (3,61mm) mating diameter. Female contact: Features large surface area (L.S.A.) closed entry design utilizing BeCu mechanical retention member.
	Size 20 Contact: 0,040 inch (1,02mm) mating diameter. Female Posiband Contact: Closed entry design.
	Size 22 Contact: 0,030 inch (0,76mm) mating diameter. Female Posiband Contact: Closed entry design.
Contact Retention In Insert:	9 lbs. (40 N).
Shells:	Male shells may be dimpled for EMI/ESD ground paths. Trapezoidally shaped shells.
Polarization:	
Mechanical Operations:	500 operations, minimum, per IEC 60512-5.

CLIMATIC CHARACTERISTICS

Temperature Range:	-40 to +85°C. The temperature range can be expended under certain conditions. Consult factory.
Helium Leak Rate At Ambient Temperature:	< 5x10 ⁻⁹ mbar.l/s under a vacuum of 1.5x10 ⁻² mbar.
Outgassing Non-Metallic Material:	Total Mass Loss – TML < 1 %. Collected Volatile Condensable Materials – CVCM < 0,1 %.

ELECTRICAL CHARACTERISTICS AT SEA LEVEL

SIGNAL CONTACTS

Contact Current Rating:	14 A nominal, size 20. 10 A nominal, size 22.
Initial Contact Resistance:	0,005 ohms maximum.
Proof Voltage:	1000 V r.m.s.

POWER CONTACTS

Contact Current Rating:	10, 15, 20, 30 and 40 amperes nominal.
Initial Contact Resistance:	0.0005 ohms maximum.
Proof Voltage:	1000 V r.m.s.

SHIELDED CONTACTS

Initial Contact Resistance:	0.008 ohms maximum.
Nominal Impedance:	50 ohms.
Insertion Loss:	-0.46 dB at 1 GHz -1.5 dB at 2 GHz.
VSWR:	1.15 average at 1 GHz. 1.56 average at 2 GHz.

Above values measured using frequency domain techniques.

HIGH VOLTAGE CONTACTS

Flash over Voltage:	3600 V r.m.s.
Proof Voltage:	2700 V r.m.s.
Initial Contact Resistance:	0.008 ohms maximum.

CONNECTOR

Insulator Resistance:	5 G ohms.
Clearance and Creepage Distance:	0.039 inch (1.0mm) minimum.
Working Voltage:	300 V r.m.s.
Residual Magnetism For Space Flight Versions :	Consult factory.

HERMETIC FEEDTHROUGH FOR SPACE OR INDUSTRIAL VACUUM APPLICATIONS



Positronic Industries
www.connectpositronic.com

XAVAC® DIMENSIONS

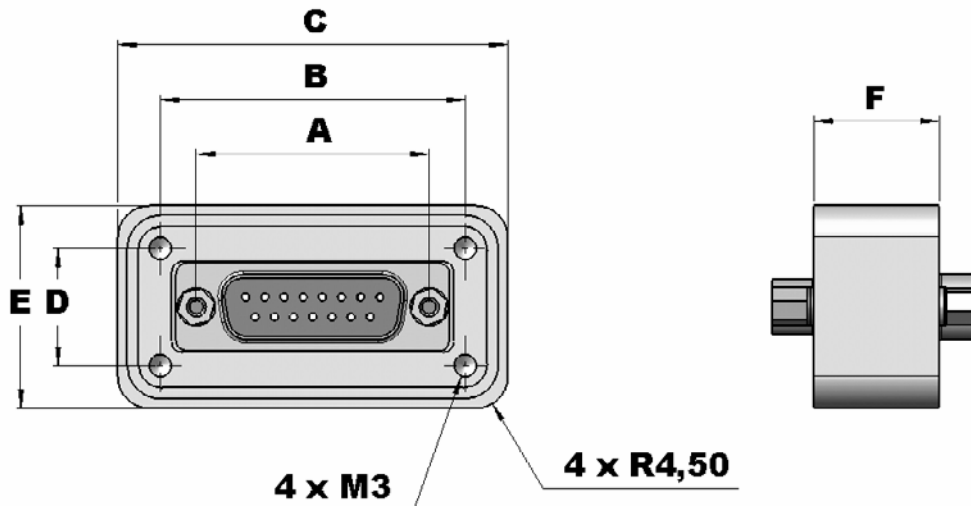

	A	B	C	D	E	F	
						Type 0-1-5*	Type 2-3-4*
SHELL SIZE 1	24,99	34,29	46,37	16,00	28,08	18	24
SHELL SIZE 2	33,32	43,64	55,79	16,76	28,92	18	24
SHELL SIZE 3	47,04	56,36	67,42	16,02	27,08	18	24
SHELL SIZE 4	63,50	73,46	85,38	16,90	28,82	18	24
SHELL SIZE 5	61,11	71,28	82,99	19,68	31,40	18	24
SHELL SIZE 6	63,50	73,26	84,38	20,88	32,00	18	24

* See ordering information: STEP 5 – Type of contacts

XAVAC® MOUNTING

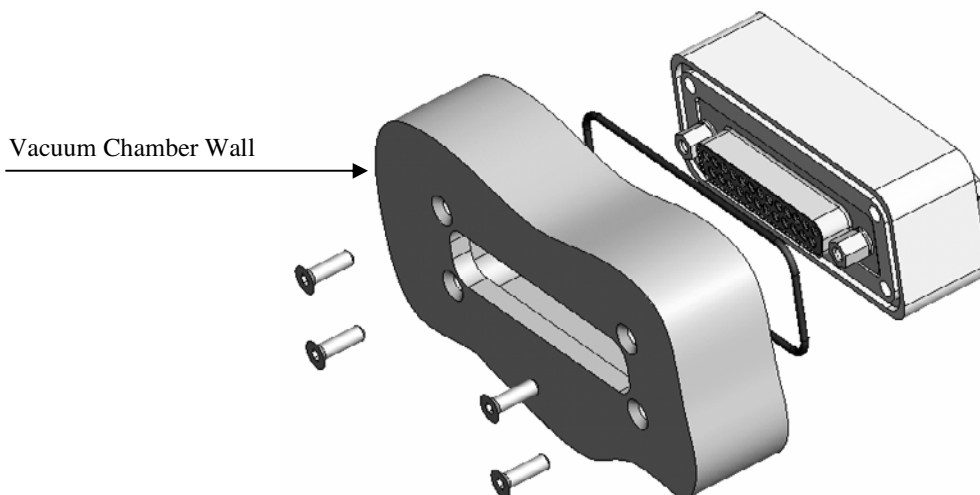

All dimensions are in mm.

All dimensions are subject to change.



HERMETIC FEEDTHROUGH FOR SPACE OR INDUSTRIAL VACUUM APPLICATIONS

XAVAC® PANEL CUTOUT INFORMATION

The depths are identical for all XAVAC® sizes

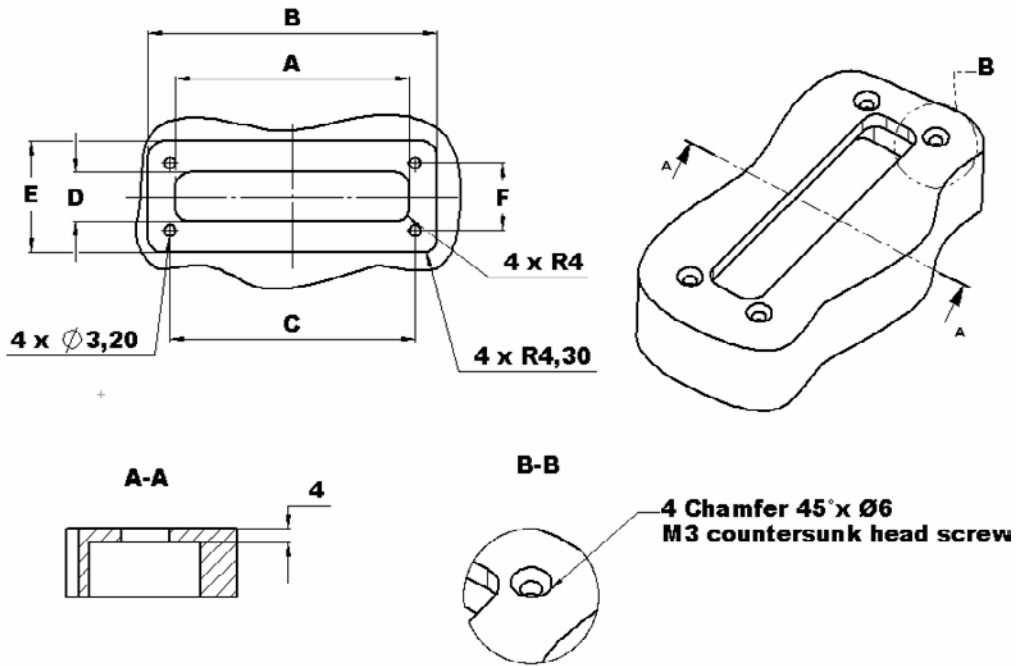

	A	B	C	D	E	F
SHELL SIZE1	32,00	47,40	34,29	12,50	29,10	16,00
SHELL SIZE2	40,30	56,80	43,64	12,50	29,90	16,76
SHELL SIZE3	54,00	68,40	56,36	12,50	28,10	16,02
SHELL SIZE4	70,50	86,40	73,46	12,50	29,80	16,90
SHELL SIZE5	68,10	84,00	71,28	15,25	32,40	19,68
SHELL SIZE6	70,50	85,40	73,26	16,80	33,00	20,88

*All dimensions are in mm.
All dimensions are subject to change.*

HERMETIC FEEDTHROUGH FOR SPACE OR INDUSTRIAL VACUUM APPLICATIONS

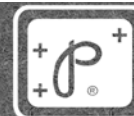

Positronic Industries
www.connectpositronic.com

ORDERING INFORMATION – CODE NUMBERING SYSTEMS

STEP	1	2	3	4	5	6
EXAMPLE	XAVAC	15	M/S	G	.0	S****
STEP 1 – BASIC SERIES XAVAC series						STEP 6 – SPECIAL OPTIONS Consult Sales Department
STEP 2 – CONNECTOR VARIANTS Normal density 9-15-25-37-50 High density 15-26-44-62-78-104 Mixed combinations (Consult Combo-D catalog) 2WK2 up to 46W4						STEP 5 – TYPE OF CONTACTS 0 : Normal density 1 : High density 2 : Power and/or mixed combinations 3 : Coax and/or mixed combinations 4 : High voltage 5* : Thermocouple contact (only normal density)
STEP 3 – CONNECTOR GENDER M/S : Male/Female Posiband M/M : Male/Male Marking inverted on the two insulators front side Not available for high density / mixed combinations S/S : Female Posiband/Female Posiband Marking inverted on the two insulators front side Not available for high density / mixed combinations						STEP 4 – TYPE OF APPLICATIONS G : Gold for Space version D : Gold and Dimpled for Space version S : Stainless-steel for Space version Residual magnetism, consult factory I : Stainless-steel for Industrial version

5*: Thermocouple contact

	Material	
5 K	Chromel ® (+) Alumel ® (-)	Position of thermocouple contacts: - The first cavity is always loaded. - Even cavities for negative contacts (-) - Odd cavities for positive contacts (+)
5 T	Copper (+) with gold flash Constantan (-)	
5 J**	Iron (+) Constantan (-)	
5E**	Chromel ® (+) Constantan (-)	

** Consult sales department